

Stacker truck 1.2 ton

BT staxio

P-series

SPE120XR

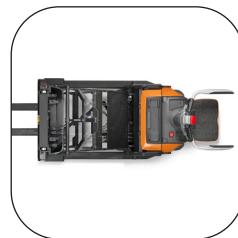

Pedestrian stacker

Specifications				SPE120XR	
Identification	1.1	Manufacturer			Toyota
	1.2	Model			SPE120XR
	1.3	Drive			Electric
	1.4	Operator type			Stand on/Pedestrian
	1.5	Load capacity/rated load	Q	kg	1200
	1.6	Load center	c	mm	600
	1.8	Load distance, centre of support arm wheel to face of forks	x	mm	DXT/DXH = 677, TX = 660
	1.9	Wheelbase	y	mm	1515
	Weight	2.1	Service weight incl. battery		kg
2.3		Axle load, mast retracted without load, drive/fork wheel		kg	1255/620
2.4		Axle load, mast extended with load, drive/fork wheel		kg	280/2795
2.5		Axle load, mast retracted with load, drive/fork wheel		kg	1235/1840
Wheels		3.1	Drive/caster/fork wheel		
	3.2	Wheel size, front		mm	250
	3.3	Wheel size, rear		mm	140
	3.7	Track width, rear	b ₁₁	mm	810/995
Dimensions	4.2	Height, mast lowered	h ₁	mm	2259
	4.3	Free lift	h ₂	mm	1934
	4.4	Lift	h ₃	mm	5350
		Lift height	h ₂₃	mm	5400
	4.5	Height, mast extended	h ₄	mm	5920
	4.8	Stand height	h ₇	mm	190
	4.9	Height of tiller in drive position, min./max. highest setting	h ₁₄	mm	1201/1413
		lowest setting	h ₁₄	mm	1101/1313
	4.10	Height of support arms	h ₈	mm	160
	4.15	Height, fork lowered	h ₁₃	mm	50
	4.19	Overall length, platform up/down	l ₁	mm	2245/2670
	4.20	Length to face of forks, platform up/down	l ₂	mm	1095/1520
	4.21	Overall width	b ₁ /b ₂	mm	900/1085
	4.22	Fork dimensions	s/e/l	mm	40/100/1150
	4.25	Width over forks	b ₅	mm	Wide = 250-750, Narrow = 250-570
	4.26	Distance between support arms	b ₄	mm	665/850
	4.28	Reach distance	l ₄	mm	790
4.31	Ground clearance, below mast	m ₁	mm	30	
4.32	Ground clearance, center of wheelbase	m ₂	mm	40	
4.33	Aisle width for pallets 1000x1200 crossways, platform up/down	A _{st}	mm	2641/3091	
4.34	Aisle width for pallets 800x1200 lengthways, platform up/down	A _{st}	mm	2618/3068	
4.35	Turning radius, platform up/down	W _a	mm	1760/2210	
4.37	Length across support arms, platform up	l ₇	mm	1830	
Performance data	5.1	Travel speed, with/without load 6 km/h version		km/h	6,0/6,0
		8 km/h version		km/h	7,0/8,0
	5.2	Lift speed, with/without load		m/s	0,20/0,36
	5.3	Lowering speed, with/without load		m/s	0,45/0,45
	5.4	Reach speed, with/without load		m/s	0,15/0,15
	5.8	Max. gradeability, with/without load ¹⁾		%	8/10
5.9	Acceleration time (over 10 m)		s	5,7	
5.10	Service brake			Electromagnetic	
Electric motor	6.1	Drive motor rating (S2 60min) 6 km/h version		kW	1,8
		8 km/h version		kW	1,8
	6.2	Lift motor rating (S3 15%)		kW	3,0
	6.4	Battery voltage, nominal capacity K _s		V/Ah	24/300
	6.5	Battery weight		kg	195-270
	6.6	Energy consumption according to VDI cycle		kWh/h	1,22
Energy consumption according to EN 16796			kWh/h	0,94	
Others	8.1	Type of drive control			Variable AC
	8.4	Sound level at the driver's ear according to EN 12 053		dB (A)	59

1) Measured according to company standard.

Data is based on standard truck and small battery.

All data are based on table configuration. Other configurations may give other values.

Truck performance and dimensions are nominal and subject to tolerances.

Toyota Material Handling products and specifications are subject to change without notice.

Mast dimensions

SPE120XR			Duplex Tele Panoramic View							Duplex Hi-Lo					Triplex Hi-Lo						
h_{23}	Lift height ($h_{13}+h_3$)	mm	2300	2450	2750	3250	3650	4100	2350	2500	2800	3300	3700	4150	3300	3700	3950	4150	4500	4800	5400
h_3	Lift	mm	2250	2400	2700	3200	3600	4050	2300	2450	2750	3250	3650	4100	3250	3650	3900	4100	4450	4750	5350
h_1	Height, mast lowered	mm	1740	1815	1965	2215	2415	2640	1740	1815	1965	2215	2415	2640	1759	1892	1975	2042	2159	2259	2459
h_2	Free lift	mm	132	132	132	132	132	132	1242	1316	1466	1716	1916	2142	1234	1366	1450	1516	1634	1734	1934
h_4	Height, mast extended	mm	2798	2948	3248	3748	4148	4598	2880	3030	3330	3830	4230	4680	3820	4219	4468	4669	5020	5320	5920

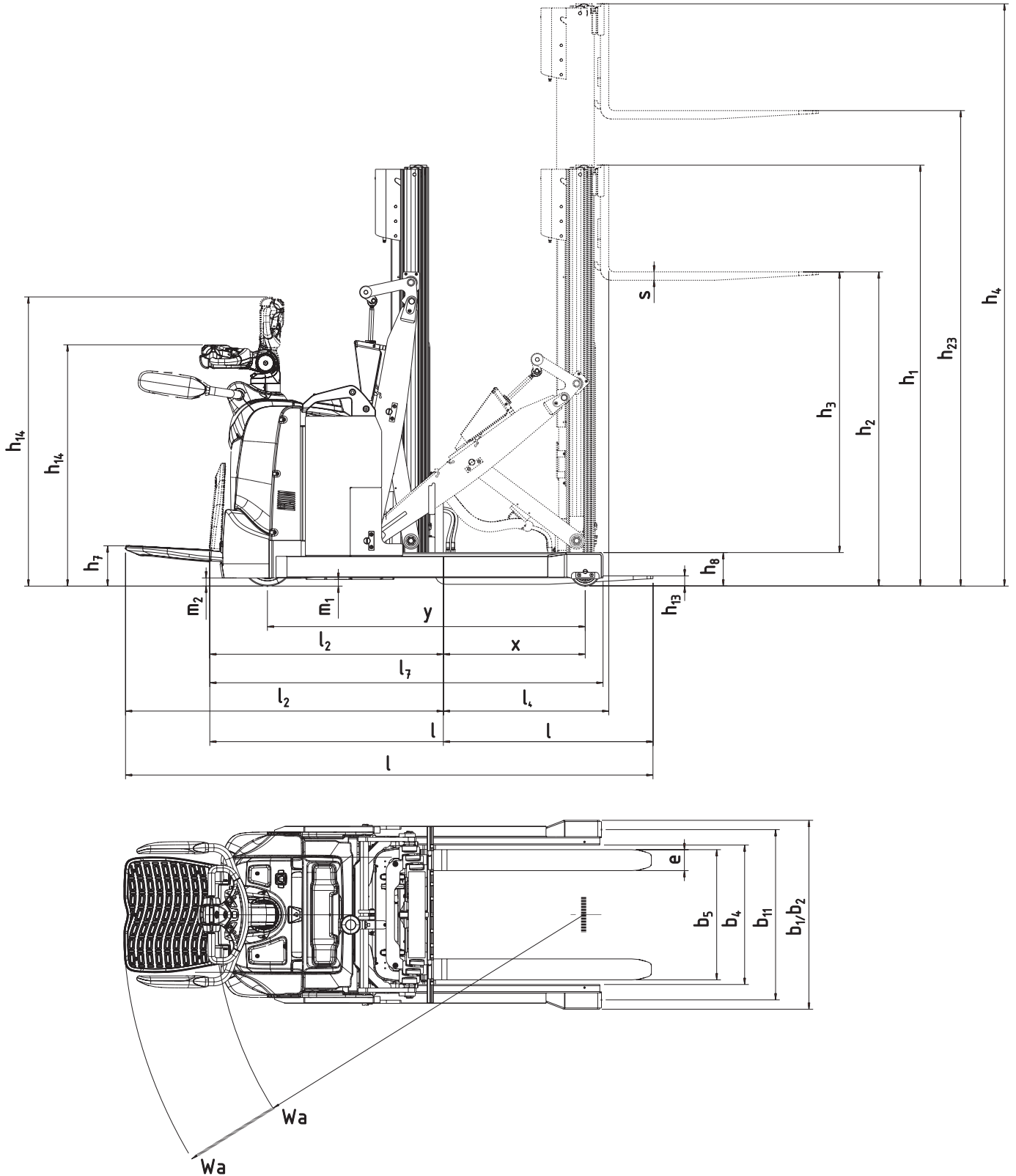

Truck features:

- 180°+ Power/Electronic steering
- Optimised Truck Performance
- Reach mast with Pantograph fork mechanism
- Mast tilt
- Adjustable fork width
- Sensi-lift
- Height adjustable tiller arm
- One-touch foldable gates
- Click-2-Creep
- Electronic fingertip controls for all functions
- Access control
- Driver-adapted programmable performance
- Easy access for maintenance
- Sideshift and spreader attachment (option)
- I_Site (option)
- Li-Ion battery (option)
- Coldstore version (option)

